

CE IE3

MADE IN ITALY

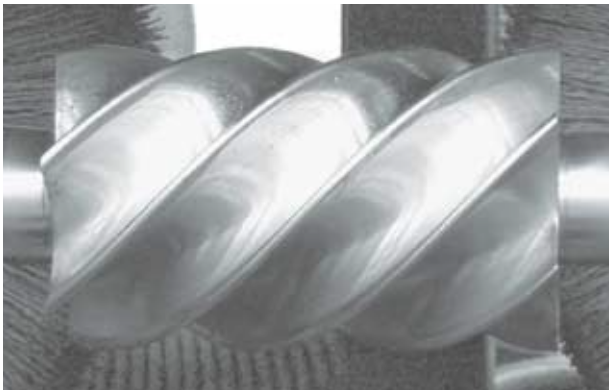

**INDUSTRIAL range**



# K-MAX

Gearless direct drive  
oil-injected  
screw compressors



Fixed and Variable Speed  
22-37 kW

# Company Profile

Fini boasts more than 60 years of experience and is one of the most important global organisations in the professional and industrial compressed air sector. Synonymous with quality and professionalism, the Fini brand not only provides one of the most comprehensive ranges in the field of rotary air compressors, but above all Fini is now established as a global reference point in terms of quality and technology recognised throughout out the industrial compressed air sector.



All Fini industrial compressors are **MADE IN ITALY** and are designed for heavy duty use and distinguished by offering unique and advanced technologies that provides energy saving solutions that work!

► Our compressors offer the ideal solution to the needs of larger-scale industry as well as smaller and mid-sized companies, where compressed air is a most important source of energy.

Fini Screw Compressors are designed for continuous duty in the most arduous operating conditions, with a special attention to reducing energy consumption, lowering operating and maintenance costs along with offering simple installation and ease of use.

► The entire production process, from project design and research through to the packaging of the final product is carried out at our facilities in Italy.

Our highly skilled work force are dedicated to supporting the manufacturing and assembling activities. The continuous control and monitoring of each manufacturing process grants the utmost precision at every step, in order to achieve the highest quality, supreme product reliability and flexibility of use.

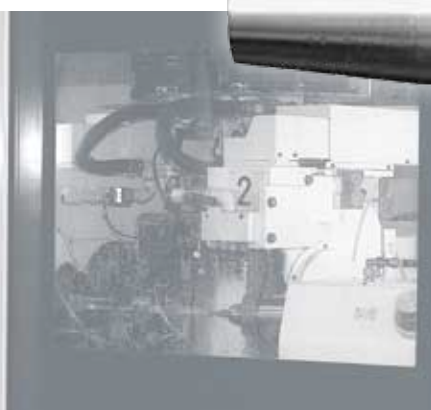

# Innovation, Quality and Know-how

Our engineering philosophy is based on the selection and highly controlled assembly of the most reliable and efficient technical solutions. The constant pursuit of excellence in quality, along with an innovative spirit and particular attention to the customers demands, are the values that have always characterised Fini and its products.

► The continuous investment in technical design and product innovation has allowed FINI to take a further step forward in the sector, with the launch of the latest **range of industrial air compressors K-MAX Series: oil-injected gearless direct-driven rotary screw compressors**, with **22** and **37 kW** power.



► During production all of the assembly and testing of products is performed on automated assembly lines that utilise the latest robotic systems. The use of the most advanced and modern machine tools in manufacturing coupled with the employment of advanced controls and processes have been a major focus for the Company representing a very significant investment in order to create products that exceed the quality standards demanded by the market.

Since 1996, the Company has certified its quality systems in compliance with UNI EN ISO 9001.

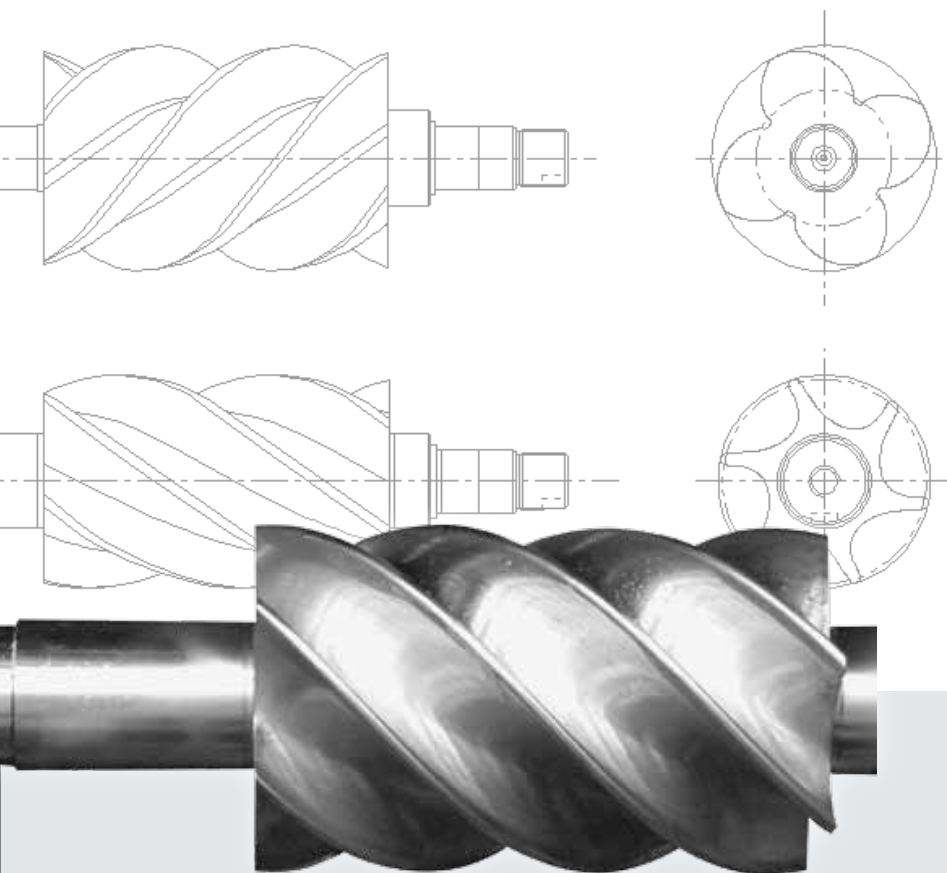

# Our TARGET: maximum efficiency, lower energy consumption and low noise impact.

The new gearless direct-driven oil injected K-MAX screw compressors have been designed to minimise energy costs, without sacrificing performance. The modularity, reduced noise and flexibility of these products provide multiple solutions suitable for different user's requirements: with or without air dryer, in fixed speed (only 7.5 bar) or variable speed version.

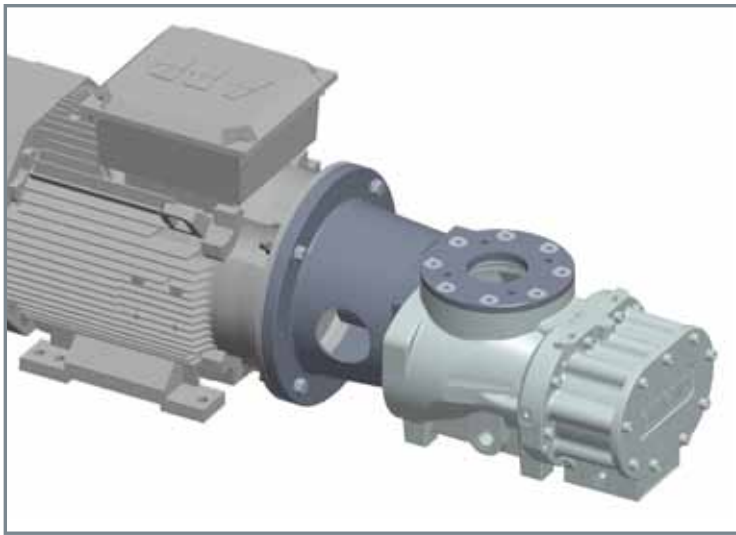

▲ FS 130 air-end, installed on K-MAX 22-08 and 22-08 ES

## ▲ Gearless direct drive transmission

The drive between the air-end and electric motor is carried out by means of gearless direct connection. Power transmission without loss can reach an advantage up to 4% compared to a normal belt driven compressor: this type of connection ensures maximum reliability and efficiency and no drive maintenance.



# Why you should choose a Fini SCREW compressor?

- ▶ To cut operating costs.
- ▶ To have the most modern, compact, efficient, reliable and quiet screw compressor.
- ▶ To provide a continuous source compressed air.
- ▶ To increase operational efficiency in all areas where compressed air is used.
- ▶ To save energy and reduce CO<sub>2</sub> emissions.



## High energy saving

The IE3 high efficiency motors, combined with high performance air-ends, allow you to cut energy costs. Moreover, IE3 motors reduce CO<sub>2</sub> emissions: an important contribution to protecting the environment.

## Plug&Play

Our K-MAX compressors are thoroughly tested in our factories to ensure they are ready for immediate use following delivery, thereby saving time and cutting installation costs.



## Low noise levels

K-MAX compressors are very quiet: efficient soundproofing materials, lower speed and radial cooling fans make them suitable for installation even near workstations.

## High reliability

The quality control and the use of components supplied by top global manufacturers ensure a long service life and extended maintenance intervals.

## High productivity

Making a product that provides the highest performance is a major focus for Fini right from the design stage. The K-MAX range continues with this philosophy.

## Compact design

The extremely compact design of these compressors allows for installation in any situation.

The air-ends, inverters and controllers have a 2-YEAR WARRANTY



AIR-END



CONTROLLER



INVERTER

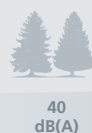

40 dB(A)



62 dB(A)



only 58 dB(A)

COMPETITORS



66-77 dB(A)



100 dB(A)



120 dB(A)

# K-MAX 22 - 38 compact design meets high performance.



▲ K-MAX 22-08



▲ K-MAX 38-08

## K-Max 22

22 kW

### Available versions:

- floor mounted compressor
- compressor + air dryer
- fixed and variable speed

### Air-end:

- FS 100 (variable speed version)
- FS 130 (fixed speed version, 7.5 bar)

## K-Max 38

37 kW

### Available versions:

- floor mounted compressor
- compressor + air dryer
- fixed and variable speed

### Air-end:

- FS 260 (fixed speed version, and variable speed 7.5 bar)
- FS 190 (variable speed version, 10-13 bar)

Controller:  
ETIV



Controller:  
ETIV



**Dryer module**

K-MAX compressors are also available with dryer ("ES" versions).  
 The refrigerated air dryer ensures the production of high quality dry compressed air that is essential to maintaining reliable systems and to ensure the highest quality of the finished product, achieves excellent performance even in unfavorable environmental conditions, and high inlet temperatures.



▲ K-MAX 22-08 ES



▲ K-MAX 38-10 VS

Code	Product	Compressor		Air delivered			Pressure		dB(A)	BSP	Weight		L x D x H (cm)
		kW	HP	l/min. (max. / min.)	m <sup>3</sup> /h (max. / min.)	c.f.m. (max. / min.)	bar	psi			kg	Lbs	
<b>FIXED SPEED</b>													
V60DR92FNM060	K-MAX 22-08	22	30	3600	216	127	7.5	109	58	1-1/4"	430	195	133 x 80 x 136
V60DU92FNM060	K-MAX 38-08	37	50	6600	396	233	7.5	109	70	1-1/2"	920	418	159 x 95 x 156
<b>FIXED SPEED WITH DRYER</b>													
V60DR92FNM160	K-MAX 22-08 ES	22	30	3600	216	127	7.5	109	58	1-1/4"	480	218	167 x 80 x 136
V60DU92FNM160	K-MAX 38-08 ES	37	50	6600	396	233	7.5	109	70	1-1/2"	1000	455	191 x 95 x 156
<b>VARIABLE SPEED</b>													
V60DR97FNM060	K-MAX 22-08 VS	22	30	3600 / 1170	216 / 68	127 / 40	7.5	109	62	1-1/4"	445	202	133 x 80 x 136
V60DS97FNM060	K-MAX 22-10 VS	22	30	3010 / 1170	181 / 70	106 / 41	10	145	60	1-1/4"	445	202	133 x 80 x 136
V60DT97FNM060	K-MAX 22-13 VS	22	30	2560 / 965	155 / 58	91 / 34	13	188	60	1-1/4"	445	202	133 x 80 x 136
V60DU97FNM060	K-MAX 38-08 VS	37	50	6600 / 2680	396 / 161	233 / 95	7.5	109	70	1-1/2"	960	436	159 x 95 x 156
V60DV97FNM060	K-MAX 38-10 VS	37	50	5400 / 1715	324 / 103	191 / 61	10	145	69	1-1/2"	880	400	159 x 95 x 156
V60DW97FNM060	K-MAX 38-13 VS	37	50	4520 / 1705	272 / 102	160 / 60	13	188	66	1-1/2"	880	400	159 x 95 x 156
<b>VARIABLE SPEED WITH DRYER</b>													
V60DR97FNM160	K-MAX 22-08 ES VS	22	30	3600 / 1170	216 / 68	127 / 40	7.5	109	62	1-1/4"	495	225	133 x 80 x 136
V60DS97FNM160	K-MAX 22-10 ES VS	22	30	3010 / 1170	181 / 70	106 / 41	10	145	60	1-1/4"	495	225	133 x 80 x 136
V60DT97FNM160	K-MAX 22-13 ES VS	22	30	2560 / 965	155 / 58	91 / 34	13	188	60	1-1/4"	495	225	133 x 80 x 136
V60DU97FNM160	K-MAX 38-08 ES VS	37	50	6600 / 2680	396 / 161	233 / 95	7.5	109	70	1-1/2"	1040	473	159 x 95 x 156
V60DV97FNM160	K-MAX 38-10 ES VS	37	50	5400 / 1715	324 / 103	191 / 61	10	145	69	1-1/2"	960	436	159 x 95 x 156
V60DW97FNM160	K-MAX 38-13 ES VS	37	50	4520 / 1705	272 / 102	160 / 60	13	188	66	1-1/2"	960	436	159 x 95 x 156

Free air delivery as per ISO 1217 Annex C, at 7 - 9.5 - 12.5 bar at the compressor outlet. ± 3 dB (A) as PNEUROP/CAGI PN-NTC 2.3.

# ETIV Advanced electronic controller

The advanced ETIV controller installed on the K-MAX models has been specially designed to ensure optimal monitoring and regulation of the operation of the compressor, allowing flexibility and complete programming, for maximum efficiency and safety.



Controller with multi-function backlight LCD graphic display, the menu is drop down type. In the main screen the display indicates:

- ▶ Working pressure (off load / load);
- ▶ Oil temperature;
- ▶ Compressor status (stand-by, off load, load);
- ▶ Fan status (off / on);
- ▶ Date and time;
- ▶ Hours remaining before maintenance;
- ▶ Inverter use percentage.

## ▶ Compressor rotation management for up to 4 units.

It is possible to connect up to 4 compressors for managing distribution of the workload in such a way to equalize the hours but also changing set pressures of the various compressors for different times.



# SMS Device Service Management System

SMS is the innovative device to allow the remote control of the compressor and to perform predictive maintenance available on screw compressors equipped with the latest ETIV controller. The device automatically sends an e-mail (up to 3 addresses to be defined during set-up) in case of an alarm and according to preset thresholds (every hour, every day, every week): this feature allows you to accurately schedule routine maintenance and to allow intervention in case of special maintenance or fault finding. Furthermore, you can have remote control from any device (tablet, smartphone, PC, notebook, etc.), via a web page, as long as it is connected to the same Internet network as the SMS device.

Predictive and targeted maintenance:

- ▶ automated e-mail in case of alarms,
- ▶ automated e-mail every hour / day / week.

Compressor remote control:

- ▶ access to the various menu levels (user, service),
- ▶ check the status of the compressor online,
- ▶ on/off control,
- ▶ no software to be installed.





# Variable speed drive

Reducing power consumption and protecting our valuable energy resources represents one of the greatest global environmental challenges of our times.

The **K-Max series** version with **22 and 37 kW** electric motor are available in a variable speed drive version, providing high performance combined with the most effective energy saving solution.

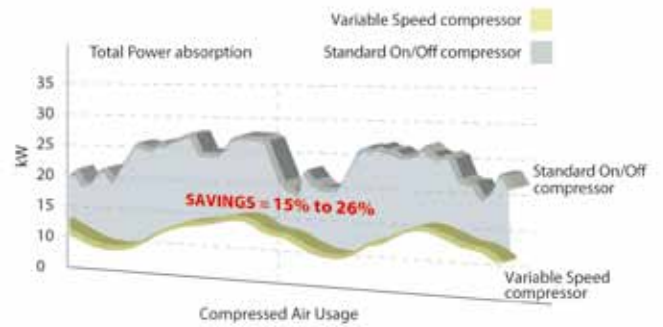

The graph below shows the significant energy saving using variable speed compressors in a typical installation.

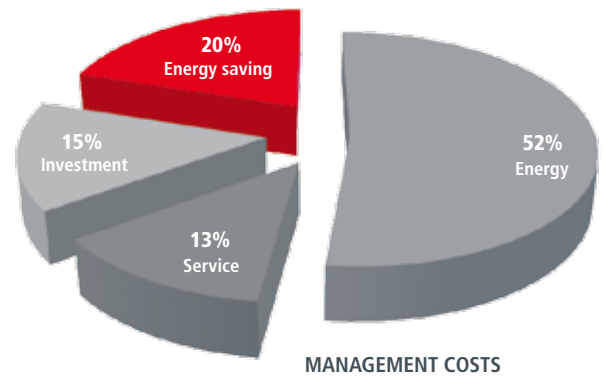

The inverter application of a leading world manufacturer, able to dynamically adjust the voltage/frequency/current values of the motor, allows the elimination of unnecessary power losses by constantly adjusting the generation of compressed air to match the real air demand, offering many proven advantages for the user in terms of reducing energy consumption:

- ▶ Continuous regulation of the motor speed and compressed air generation to precisely match the air demand.
- ▶ The air output is constantly adjusted between 40% and 100% of the compressor full capacity.
- ▶ Constant and accurate air pressure.
- ▶ Energy consumption is proportional to the delivered compressed air.

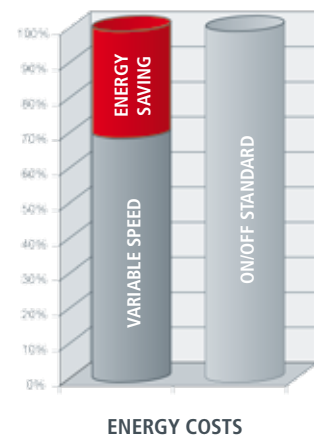

Designed for a long service life



# Noise and temperature under control



## ■ Innovative cooling system

The cooling system is among the most innovative in the field: a thermostatic controlled centrifugal fan keeps the temperature of the entire compressor to specific tolerance and at a constant level, avoiding temperature peaks that can be harmful for the correct operation of the compressor. The action of the fan, combined with the efficiency of the oversized oil cooler, guarantees the ideal operation of the compressor in differing and even extreme climatic conditions. The "silent" fans, along with the specially designed labyrinth ventilation and the use of top quality soundproofing materials ensure one of the lowest acoustic levels of any air compressor.



## ■ Pre-filtering panel

The pre-filtering panel separates incoming dust and keeps the inside of the machine clean, thereby increasing the longevity of internal components and reducing operating temperature.



## ■ High performance oversized air-ends

The special design of the rotor profile ensures high performance levels.



## ■ SPIN-ON filters

The oil filter and oil-separator filter are easy to remove and replace, whilst offering a long service life with low maintenance costs.



## ■ Intake regulator

The electro-pneumatic system controls the operation of the compressor to ensure minimum pressure when operating under no-load conditions and maximum energy savings upon start-up.



## ■ Easy to transport

Thanks to the easily removable panel located at the base of the compressor, the machine can be effortlessly transported with a transpallet or a forklift truck. The panel is then replaced following installation ensuring considerably lower noise levels and improves aesthetics.



## ■ High-efficiency IE3 motors

The "Premium Efficiency" IE3 motors by a top global manufacturer, combined with high-efficiency air-ends, ensure lower energy costs. Moreover, IE3 motors help to reduce CO<sub>2</sub> emissions.

# HRS Heat Recovery System

**HRS is a system for the recovery of the heat generated by the screw compressors, for the production of hot water.**

Most of the energy used to produce compressed air is actually converted into heat: up to 90% of this energy is reusable! About 75% of the energy used is found in the lubrication and cooling circuit and can be used as a heat source, the remaining 15% is contained in the compressed air. It is therefore easier to produce the compressed air which enters the network. It is therefore quite simple to recover the thermal energy (for alternative use) in the compression process... valuable energy that is normally wasted!



▶ Plate oil-water heat exchanger

▶ Water pump

The HRS system can be used on all oil-injected screw compressors.

## HEAT OF COMPRESSION

- 4% Heat remaining in the air
- 2% Losses by radiation
- 13% Heat removed from the air cooler
- 72% Heat removed from the oil cooler
- 9% Heat radiated by the electric motor

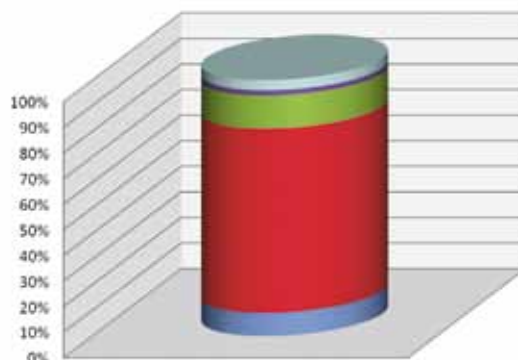

# Recover energy - Save money!



How great the recovery of energy actually is, depends of course on the size of the compressors and the type of replaced energy (electricity, gas, heating oil), but the investment becomes very interesting for the compressors starting from 11 kW installed power. Given the current energy costs, the return on investment of a typical heat recovery system can be as short as 6 months with less than 2 years being the standard (with reference to a plate heat exchanger for heating systems).

Heat recovery is a real opportunity to increase the effectiveness of a compressed air system, the impact on energy costs allows greater savings, up to 3 times compared to even the most efficient compressor.



# Optimised control in the compressor room

Many compressed air stations include several compressors: EasyX4 is a weekly programmable sequencer, capable of configuring up to 4 compressors, based on the amount of air actually required.

**EasyX4 is the easiest solution for compressor sequencing and supervision over complex systems of compressors, up to 4 units: fixed or variable speed.**

The programming is intuitive. It is sufficient to set the 4 pressure ranges (if 4 is the number of connected units) and later define at what time the entire compressor station shall start and stop, assigning at which pressure each compressor must work.



- Three programming levels:**
- ▶ **MANUAL:** compressors are fixed to a given operational pressure range;
  - ▶ **AUTOMATIC:** with pressure range swapping after a programmable time interval;
  - ▶ **GROUP PROGRAMMING:** where compressors can be switched within groups.

# Long Life Kit for screw compressors scheduled maintenance

- ▶ **FSN original spare parts** have been rigorously selected, checked and tested by specialised technicians to ensure the utmost efficiency and endurance of the compressor. The parts are stocked in our "LOGIMAT" centralised and automated warehouse in Zola Predosa (BO) - Italy, where 12,000 part codes on 10,000 sqm are managed every day.
- ▶ Specialised staff are continuously in contact with our distribution centres worldwide, to deliver spare parts to our customers in the shortest possible time.
- ▶ The use of **FSN Long Life Kit**, specifically studied for screw compressors, extends maintenance intervals, cutting down service costs and ensuring consistent product performance.



Maintenance interval, using original parts **+20%**

	2,000 h (or every year)	4,000 h (or every year)	12,000 h
<b>K-MAX 22 - 37 kW</b>	1 Air filter cartridge	<b>KIT B</b>	<b>KIT E</b>
		1 Air filter cartridge 1 Oil filter cartridge 1 Separator cartridge (22 kW) - 2 Separator cartridges (37 kW) 1 Oil check valve (22 kW) - 2 Oil check valves (37 kW) 1 Prefilter	1 Kit 4,000 h 1 Solenoid valve
<b>K-MAX VS 22 - 37 kW</b>	1 Air filter cartridge	1 Kit 4,000 h 1 Electric cabinet prefilter	1 Kit 4,000 h VS 1 Solenoid valve

We recommend to change oil at the indicated intervals (see the user's manual) or every year. We suggest to use our RotEnergyPlus oil (NOT INCLUDED IN THE LONG LIFE KIT).

## RotEnergy synthetic base lubricants

- ▶ FSN lubricants are specially designed for rotary screw compressors to achieve rapid water separation, lower friction, enhanced energy savings, longer maintenance intervals and excellent bearing lubrication while offering superior rust and corrosion protection.
- ▶ RotEnergyFood is a high quality food-grade rotary compressor lubricant specifically designed for use in the food and beverage industries to meet their production quality standards.



#60000018	RotEnergyPlus 46 cSt - 1 x 3.25 kg (3.75 lt) package
#60000009	RotEnergyPlus 46 cSt - 4 x 3.25 kg (3.75 lt) packages
#60000007	RotEnergyPlus 46 cSt - 1 x 16 kg (18.5 lt) package
#60000012	RotEnergyPlus 46 cSt - 1 x 175 kg (210 lt) can
#60000014	RotEnergyFood 46 cSt - 4 x 3.25 kg (3.75 lt) packages
#60000016	RotEnergyFood 46 cSt - 1 x 16 kg (18.5 lt) package
#60000017	RotEnergyFood 46 cSt - 1 x 180 kg (207 lt) can

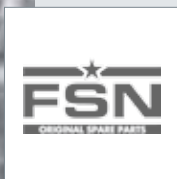

- ▶ All the exploded drawings and the spare parts lists for every compressor model are available at any time on the Fini and FSN websites: [www.finicompressors.com](http://www.finicompressors.com) - [www.fsnspareparts.com](http://www.fsnspareparts.com)
- ▶ Our "Hot-Line" service is able to prepare and ship urgent orders on the same day.

## A wide range of solutions for industrial applications



**K-Max 5.5-15**  
Gearless direct drive oil-injected screw compressors, from 5.5 to 15 kW power, fixed and variable speed.



**Micro - Plus**  
Belt-driven oil-injected rotary screw compressors, from 2.2 to 75 kW power, fixed and variable speed.



**Tera SD**  
Gearless direct drive oil-injected screw compressors, from 75 to 250 kW power, fixed and variable speed.



**OS Scroll**  
Oil-free spiral scroll compressors, from 2.2 to 22 kW power, single or multi-scroll, fixed and variable speed.



**Air Treatment**  
Air dryers, air filters and a wide range of products for the compressed air treatment.



**FINI NUAIR S.p.A.**

Registered office and Headquarter: Via Einaudi, 6 - 10070 Robassomero (TO) - Italy

Production plant: Via Toscana, 21 - 40069 Zola Predosa (BO) - Italy

Tel.: +39 011 9233000 - Fax: +39 011 9241138

[www.finicompressors.com](http://www.finicompressors.com) - [info@finicompressors.it](mailto:info@finicompressors.it)

